



Electrolux
PROFESSIONAL

**Modular Cooking Range Line
thermaline 90 - 2 Zone Full Surface
Induction Top on Open Base, 1 Side,
H=700 - H3 -Marine**

ITEM # _____

MODEL # _____

NAME # _____

SIS # _____

AIA # _____



589852 (MCJQAEIDM)

Full Surface Induction Top
on Open Base, 2 zones,
one-side operated - H3 -
Marine

Short Form Specification

Item No. _____

Unit constructed according to DIN 18860_2 with 20 mm drop nose top and 70 mm recessed plinth. Internal frame for heavy duty sturdiness in stainless steel. 2 mm top in 1.4301 (AISI 304). Flat surface construction, easily cleanable. THERMODUL connection system enables seamless worktop when units are connected and avoids soil penetrating. Large multi-coil glass ceramic surface without any "dead" spots allows for quick and easy cleaning. Features 9 power levels with fast deployment to full heating power and very low heat dissipation to the kitchen. Overheat protection switches off the supply in case of overheating. Metal knobs with embedded hygienic silicon "soft" grip enable easier handling and cleaning. IPX5 water resistance certification.
Configuration: Freestanding, one-side operated, on H3 base, hygienic class H3.

Main Features

- Almost the entire surface of the ceramic plate can be used without "dead" spots.
- Fast deployment with full heating power immediately.
- Low heat dissipation to the kitchen.
- Overheat protection: the temperature sensor switches off the supply in case of overheating.
- Pans can easily be moved from one area to another without lifting.
- The large surface multi-coil induction top offers a substantial increase in pan and pot capacity thanks to the seamless transition between individual heating zones, ideal for à la carte operation.
- The smooth glass-ceramic surface can be quickly and easily cleaned, thus providing maximum hygiene.
- All major components may be easily accessed from the front.
- THERMODUL connection system creates a seamless work top when units are connected to each other thus avoiding soil penetrating vital components and facilitating the removal of units in case of replacement or service.
- Metal knobs with embedded hygienic "soft-touch" grip for easier handling and cleaning. The special design of the controls prevents infiltration of liquids or soil into vital components.
- Large visible digital display manufactured in tempered glass to resist heat and chemicals, showing temperatures or power settings. The display also shows on/off status of the appliance and on/off status of the heating elements.
- 9 power levels.

Construction

- Control light for each zone.
- 2 mm top in 1.4301 (AISI 304).
- Unit constructed according to DIN 18860_2 with 20 mm drop nose top and 70 mm recessed plinth.
- Flat surface construction with minimal hidden areas to easily clean all surfaces
- IPX5 water resistance certification.
- Internal frame for heavy duty sturdiness in stainless steel.

Sustainability



- This model is compliant with Swiss Energy Efficiency Ordinance (730.02).

APPROVAL: _____



Experience the Excellence
www.electroluxprofessional.com

Optional Accessories

| | | |
|---|------------|--------------------------|
| • Scraper for cook tops | PNC 910601 | <input type="checkbox"/> |
| • Connecting rail kit, 900mm | PNC 912502 | <input type="checkbox"/> |
| • Stainless steel side panel, 900x700mm, freestanding | PNC 912512 | <input type="checkbox"/> |
| • Portioning shelf, 500mm width | PNC 912523 | <input type="checkbox"/> |
| • Portioning shelf, 500mm width | PNC 912553 | <input type="checkbox"/> |
| • Folding shelf, 300x900mm | PNC 912581 | <input type="checkbox"/> |
| • Folding shelf, 400x900mm | PNC 912582 | <input type="checkbox"/> |
| • Fixed side shelf, 200x900mm | PNC 912589 | <input type="checkbox"/> |
| • Fixed side shelf, 300x900mm | PNC 912590 | <input type="checkbox"/> |
| • Fixed side shelf, 400x900mm | PNC 912591 | <input type="checkbox"/> |
| • Endrail kit, flush-fitting, left | PNC 913111 | <input type="checkbox"/> |
| • Endrail kit, flush-fitting, right | PNC 913112 | <input type="checkbox"/> |
| • Endrail kit (12.5mm) for thermaline 90 units, left | PNC 913202 | <input type="checkbox"/> |
| • Endrail kit (12.5mm) for thermaline 90 units, right | PNC 913203 | <input type="checkbox"/> |
| • Stainless steel side panel, left, H=700 | PNC 913222 | <input type="checkbox"/> |
| • Stainless steel side panel, right, H=700 | PNC 913223 | <input type="checkbox"/> |
| • T-connection rail for back-to-back installations without backsplash (to be ordered as S-code) | PNC 913227 | <input type="checkbox"/> |
| • Endrail kit, (12.5mm), for back-to-back installation, left | PNC 913251 | <input type="checkbox"/> |
| • Endrail kit, (12.5mm), for back-to-back installation, right | PNC 913252 | <input type="checkbox"/> |
| • Endrail kit, flush-fitting, for back-to-back installation, left | PNC 913255 | <input type="checkbox"/> |
| • Endrail kit, flush-fitting, for back-to-back installation, right | PNC 913256 | <input type="checkbox"/> |
| • Side reinforced panel only in combination with side shelf, for freestanding units | PNC 913260 | <input type="checkbox"/> |
| • Side reinforced panel only in combination with side shelf, for back-to-back installations, left | PNC 913275 | <input type="checkbox"/> |
| • Side reinforced panel only in combination with side shelf, for back-to-back installation, right | PNC 913276 | <input type="checkbox"/> |
| • Filter W=500mm | PNC 913664 | <input type="checkbox"/> |
| • Stainless steel dividing panel, 900x700mm, (it should only be used between Electrolux Professional thermaline Modular 90 and thermaline C90) | PNC 913672 | <input type="checkbox"/> |
| • Stainless steel side panel, 900x700mm, flush-fitting (it should only be used against the wall, against a niche and in between Electrolux Professional thermaline and ProThermetic appliances and external appliances - provided that these have at least the same dimensions) | PNC 913688 | <input type="checkbox"/> |

Front

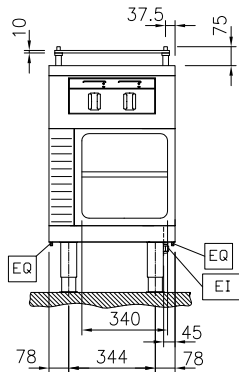

Side

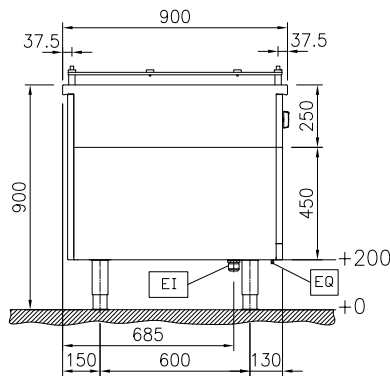

EI = Electrical inlet (power)
 EQ = Equipotential screw

Top

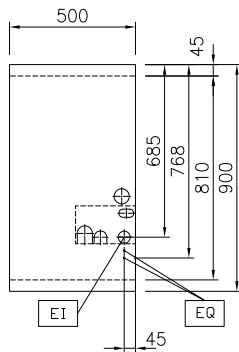
Electric

Supply voltage: 440 V/3 ph/50/60 Hz
 Total Watts: 14 kW

Key Information:

External dimensions, Width: 500 mm
 External dimensions, Depth: 900 mm
 External dimensions, Height: 700 mm
 Storage Cavity Dimensions (width): 340 mm
 Storage Cavity Dimensions (height): 330 mm
 Storage Cavity Dimensions (depth): 740 mm
 Net weight: 51 kg

Configuration: On Base;One-Side Operated
 Front Plates Power: 7 - 0 kW
 Back Plates Power: 7 - kW
 Front Plates dimensions: 420x370
 Back Plates dimensions: 420x370
 Induction Top Dimensions (width): 500 mm
 Induction Top Dimensions (depth): 900 mm

Sustainability

Current consumption: 19 Amps